

Press-in – Technology and board connectors

Page

General information ..... **20.02**

**harmik®**

Technical characteristics ..... **20.05**

I/O connectors, straight ..... **20.06**

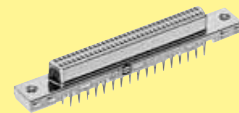

Intra cabinet connectors, straight ..... **20.07**

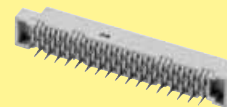

**D-Sub – S**

Technical characteristics ..... **20.08**

Press-in connectors, straight ..... **20.10**

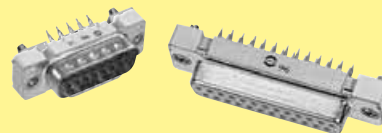

**SEK**

Technical characteristics ..... **20.14**

Low profile press-in connectors, straight ..... **20.15**

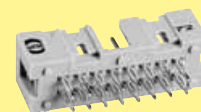

Solderless termination for connectors has proven to be reliable for decades. Today the use of press-in connectors encompasses all fields of electrical and electronical applications.

Pressing of electrical components, mainly connectors, is characterised through the matching of the connector pin and the plated through hole of the pcb. Whereas the desired electrical characteristics can be attained relatively independant from the design of the press-in zone, the mechanical characteristics of the press-in zone are crucial for the reliable assembly of connectors where pcb's have different surfaces.

Although the scope of requirements at the press-in process is generally defined in time-tested specifications, the novel press-in zones should offer an optimal handling and a reliable termination. Essentially, this is guaranteed through the design of the press-in zone and the meticulous observance of tolerances. HARTING has been using FEM simulations for the calculation and optimisation of press-in zones for a long period of time. This expertise allows us to simulate various pcb configurations very accurate.

Due to variety of different connector contact designs, the press-in zone has been designed to fit perfectly to the contact metal thickness and the plated through hole dimensions and tolerances.

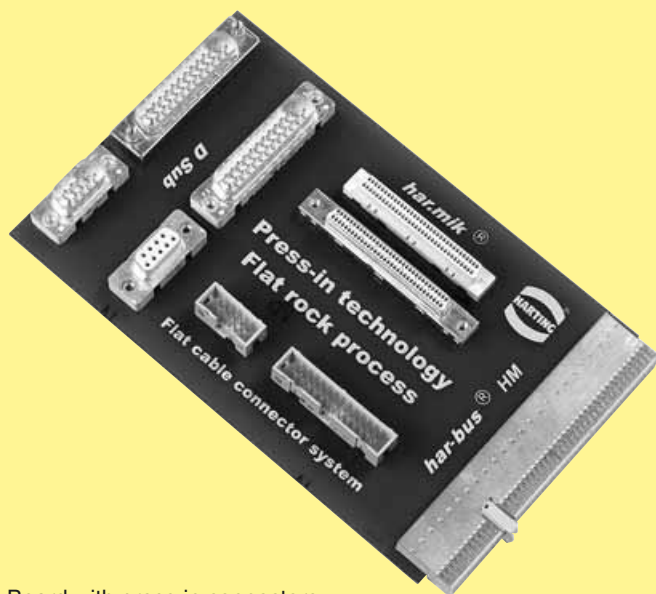

Board with press-in connectors

## *harmik*<sup>®</sup>

The patented contact design allows 20 % more tolerance on the plated through hole of 0.6 mm than the standard tolerance of  $0.6^{+0.07}_{-0.05}$  mm.



## *D-Sub*

The terminating spoon shape of the contact provides a reliable vertical position of the connector for better alignment during insertion.

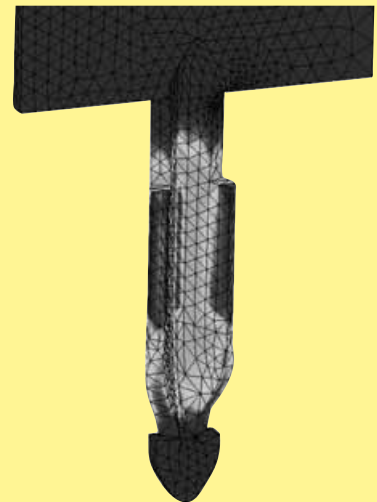

## *SEK*

The renowned needle eye allows for compensation of tolerances of pcb surface properties. The excessive material is displaced within the plated through hole whereby a gastight connection is assured.

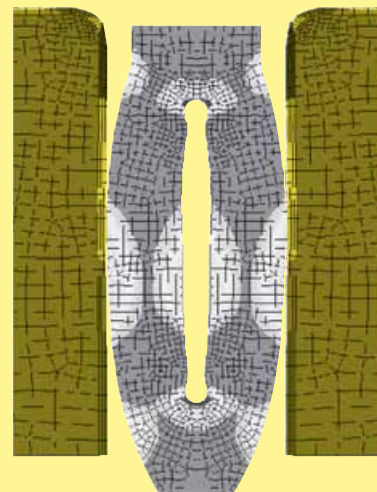

Due to the high deformation resistance and resilience of **harpress**® contacts, they can be easily and repeatedly removed in case of repairs without impairment to their functioning.

Today tinned surfaces are widely used as a standard, the pcb technology trends are moving to low tin or tin free surfaces. Cu, Pd, Au and Ag are the important alternatives. Specific parameters and particularly different friction factors of these surfaces make high demands on press-in zones.

**harpress**® is extremely versatile and offers a reliable electrical contact, therefore it is especially well suited for applications with these surfaces.

Please contact us for detailed test reports.

## Benefits of the press-in technology

- Thermal shocks associated with the soldering process and the risk of the board malfunction are avoided.
- No need for the subsequent cleaning of the assembled pcb's

## Recommended configuration chart for tinned plated through holes

|                      | Plated through hole |               |
|----------------------|---------------------|---------------|
|                      | 0.6 mm              | 1 mm          |
| Drilled hole Ø [mm]  | 0.71 - 0.74         | 1.12 - 1.15   |
| Cu thickness [µm]    | 30 - 60             | 25 - 75       |
| Sn thickness [µm]    | 5 - 20              | 5 - 15        |
| Plated hole Ø [mm]   | 0.55 - 0.67         | 0.94 - 1.09   |
| Board thickness [mm] | 1.6 - 3.2           | 1.6 - 3.2     |
| Connector range      | har-mik             | SEK and D-Sub |

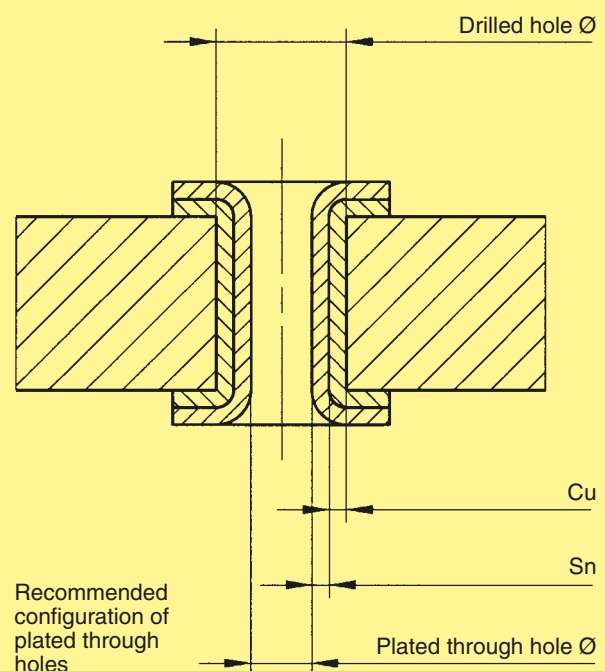
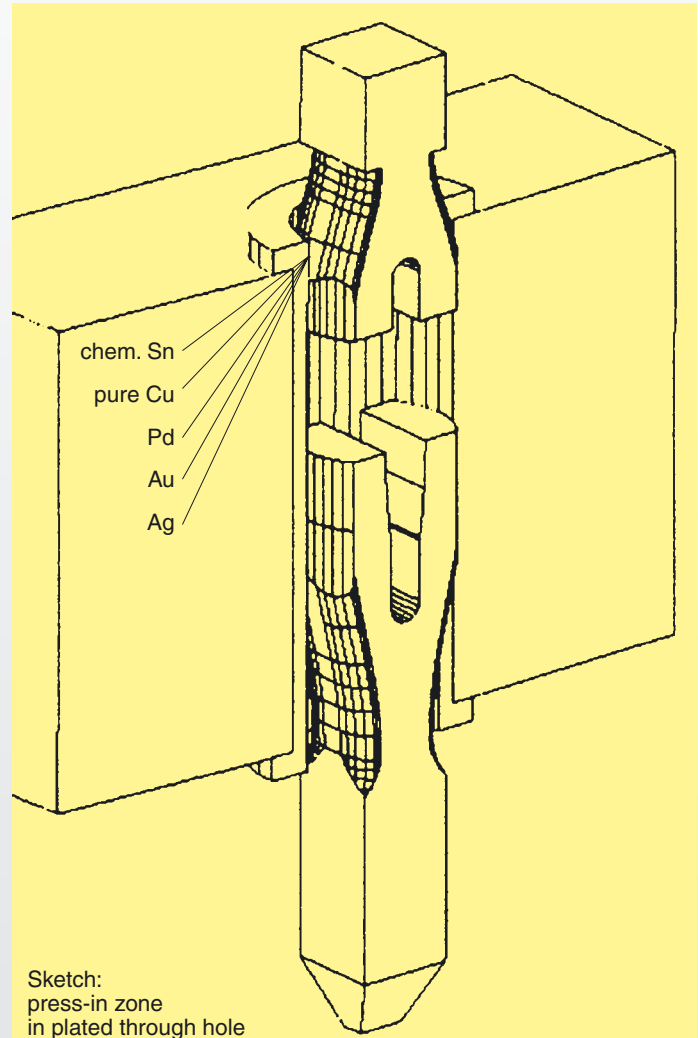

## Quality control of the press-in termination

The press-in force correlates with the diameter of the plated through hole and with the friction coefficient of the surface; therefore it can be used for a continuous monitoring of the process.

The retention force, as an indirect measure of the normal force, serves to qualify the process or random tests

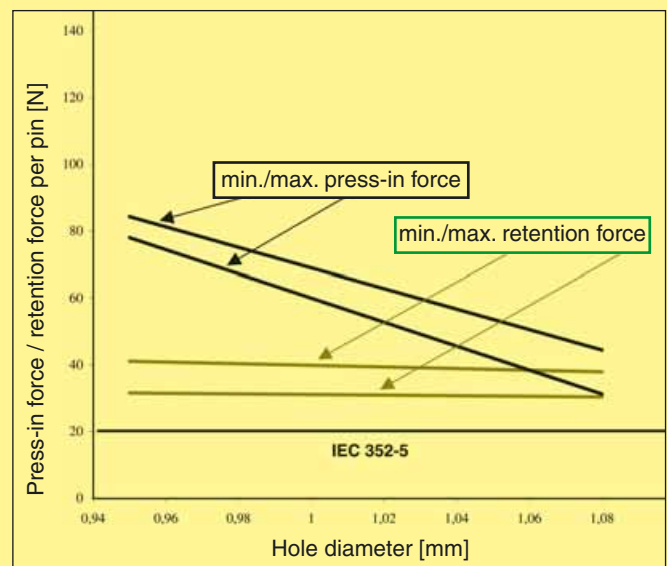

Typical press-in and retention forces for the D-Sub press-in zone

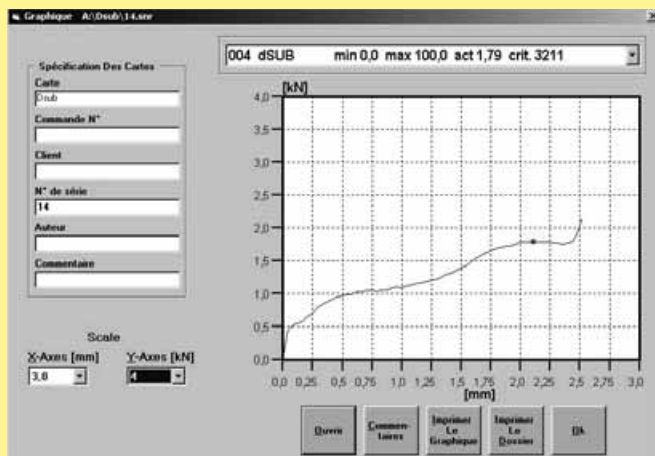

The automatic press-in machines of HARTING feature a graphical user interface for monitoring the process and the quality of the press-in termination (see chapter 30).



X-ray photo of a pressed-in connector

|   |  |
|---|--|
| Number of contacts                            | 68   |
| Pitch   | 1.27 mm  |
| Working current                               | 1 A  |
| Working voltage                               | 240 V ~  |
| Test voltage $U_{r.m.s.}$                     | 750 V  |
| Contact resistance                            | $\leq 30 \text{ m}\Omega$  |
| Insulation resistance                         | $\geq 10^3 \text{ M}\Omega$  |
| Temperature range                             | -55 °C ... + 105 °C  |
| <b>Materials</b>                              |  |
| Moulding                                      | Thermoplastic resin<br>glass-fibre filled UL 94-V0   |
| Contacts                                      | Copper alloy   |
| <b>Contact surface</b>                        |  |
| Contact zone                                  | selectively gold-plated<br>acc. to performance level   |
| Metal shell                                   | Die cast zamac or stamped<br>steel, nickel-plated  |
| <b>Press-in</b>                               |  |
| Insertion process                             | Flat rock  |
| Maximum press-in force<br>per contact         | 100 N  |
| Minimum push out force<br>per contact         | 15 N   |
| Number of repairs                             | 2  |
| Diameter of pcb plated<br>through holes       | $\varnothing 0.6^{+0.07}_{-0.05} \text{ mm}$   |
| Recommended pcb holes<br>for press-in process | Hole : $\varnothing 0.71 - 0.74 \text{ mm}$<br>Cu : 30 – 60 $\mu\text{m}$<br>Sn : 5 – 20 $\mu\text{m}$ |
| Pcb thickness                                 | 1.6 – 3.2 mm   |

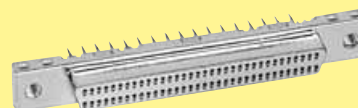
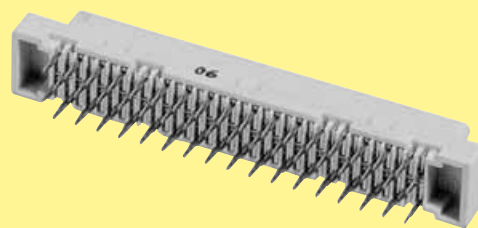

Number of contacts

68

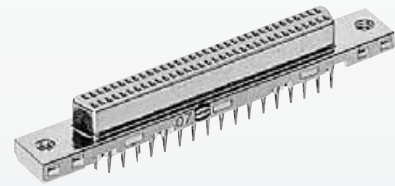

Female connectors, straight

| Identification                               | No. of contacts | Part No.       |
|--|-----------------|----------------|
| Female connector with straight press-in pins | 68              | 60 02 068 5322 |

Dimensions

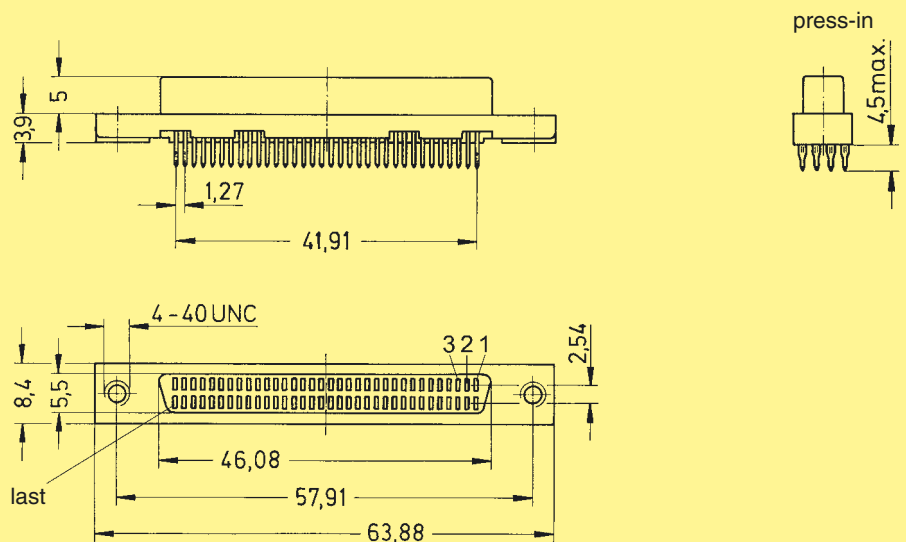

Board drillings  
(Components side)

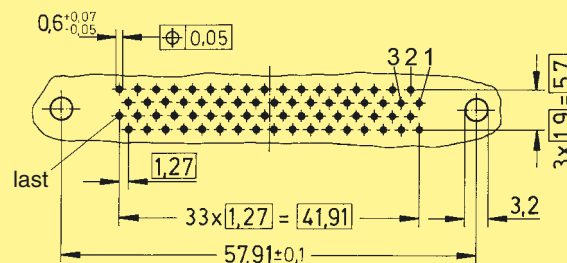

Dimensions in mm

Press-in technology

Number of contacts

68



Female connectors, straight

| Identification                               | No. of contacts | Part No.       |
|--|-----------------|----------------|
| Female connector with straight press-in pins | 68              | 60 05 068 5322 |

Dimensions

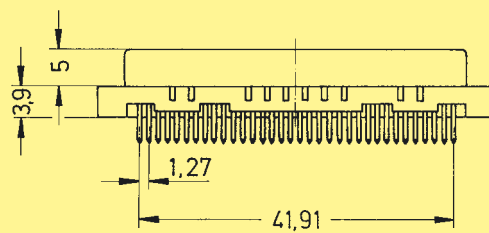

press-in

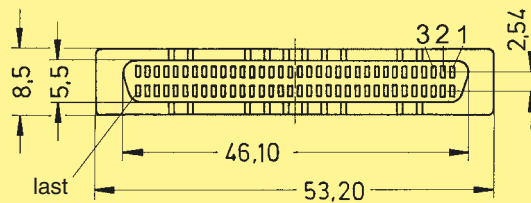
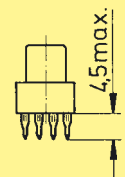

Board drillings  
(Components side)

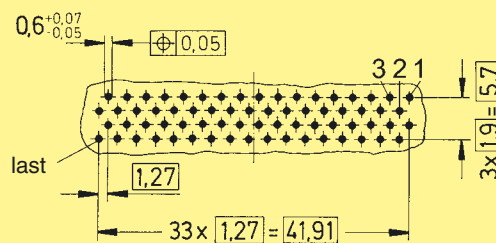

Dimensions in mm

Number of contacts 9, 15, 25, 37, 50  
UL recognized

Working current  
see current carrying capacity chart  
Stamped contacts 6.5 A max.

Test voltage  $U_{r.m.s.}$  1 kV

Clearance and creepage  $\geq 1.0$  mm

Contact resistance  $\leq 10$  m $\Omega$   
Insulation resistance  $\geq 10^{10}$   $\Omega$

Temperature range -55 °C ... + 125 °C  
The higher temperature limit includes the local ambient and heating effect of the contacts under load

Terminations Recommended PCB through holes

|  | Signal pin | Grounding pin |
|--|------------|---------------|
|--|------------|---------------|

| Tin-lead plated PCB | Hole        | 1.15 <sup>-0.03</sup> | 3.15 <sup>±0.025</sup> |
|---------------------|-------------|-----------------------|------------------------|
|                     | Cu          | 25-75 $\mu$ m         | 25-75 $\mu$ m          |
|                     | Sn          | 5-15 $\mu$ m          | 4-10 $\mu$ m           |
|                     | Plated hole | 0.94-1.09 mm          | 3.0-3.15 mm            |

| Chemical tin-plated PCB | Hole        | 1.05 <sup>-0.03</sup> | 3.15 <sup>±0.025</sup> |
|-------------------------|-------------|-----------------------|------------------------|
|                         | Cu          | 25-50 $\mu$ m         | 25-50 $\mu$ m          |
|                         | Sn          | 0.8-1.0 $\mu$ m       | 0.8-1.0 $\mu$ m        |
|                         | Plated hole | 1.00-1.10 mm          | 3.0-3.15 mm            |

| Au / Ni plated PCB | Hole         | 1.15 <sup>-0.03</sup> | 3.15 <sup>±0.025</sup> |
|--------------------|--------------|-----------------------|------------------------|
|                    | Cu           | 25-50 $\mu$ m         | 25-50 $\mu$ m          |
|                    | Ni           | 3-7 $\mu$ m           | 4-7 $\mu$ m            |
|                    | Au           | 0.05-0.12 $\mu$ m     | 0.05-0.12 $\mu$ m      |
| Plated hole        | 1.00-1.10 mm | 3.0-3.15 mm           |                        |

| Silver plated PCB | Hole        | 1.15 <sup>-0.03</sup> | 3.15 <sup>±0.025</sup> |
|-------------------|-------------|-----------------------|------------------------|
|                   | Cu          | 25-50 $\mu$ m         | 25-50 $\mu$ m          |
|                   | Ag          | 0.1-0.3 $\mu$ m       | 0.1-0.3 $\mu$ m        |
|                   | Plated hole | 1.00-1.10 mm          | 3.0-3.15 mm            |

| OSP copper plated PCB | Hole        | 1.15 <sup>-0.03</sup> | 3.15 <sup>±0.025</sup> |
|-----------------------|-------------|-----------------------|------------------------|
|                       | Cu          | 25-50 $\mu$ m         | 25-50 $\mu$ m          |
|                       | Plated hole | 1.00-1.10 mm          | 3.0-3.15 mm            |

PCB board thickness: 1.6-3.2 mm

Materials Mouldings and hoods Liquid Crystal Polymer (LCP)  
UL 94-V0

Contacts Copper alloy

Contact surface Contact zone selectively gold-plated  
acc. to performance level<sup>1)</sup>

Metal shell Plated steel

Insertion and withdrawal force

Connector on P.C.B.  
Press-in without grounding pins  
– insertion max. per contact: 120 N  
– withdrawal min. per contact: 20 N  
Press-in with grounding pins  
– insertion max. per grounding pin: 250 N  
– withdrawal min. per grounding pin: 30 N

Mating force  
9 way  $\leq 30$  N  
15 way  $\leq 50$  N  
25 way  $\leq 83$  N  
37 way  $\leq 123$  N  
50 way  $\leq 167$  N

Current carrying capacity

The current carrying capacity is limited by maximum temperature of materials for inserts and contacts including terminals. The current capacity-curve is valid for continuous, not interrupted current-loaded contacts of connectors when simultaneous power on all contacts is given, without exceeding the maximum temperature.

Control and test procedures according to DIN IEC 60 512.

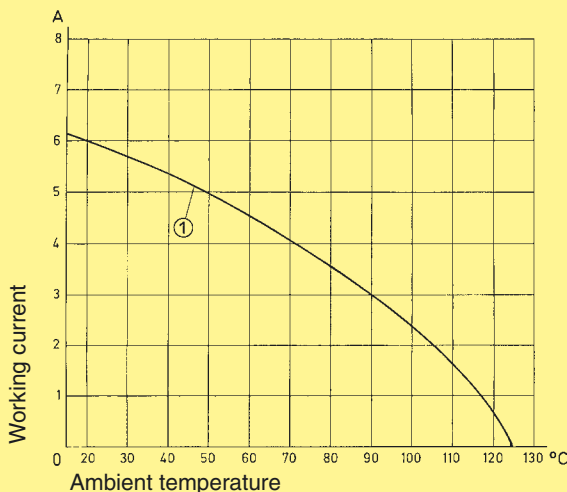

Example: 25 way connector  
① Stamped contacts

Contact arrangement View from termination side

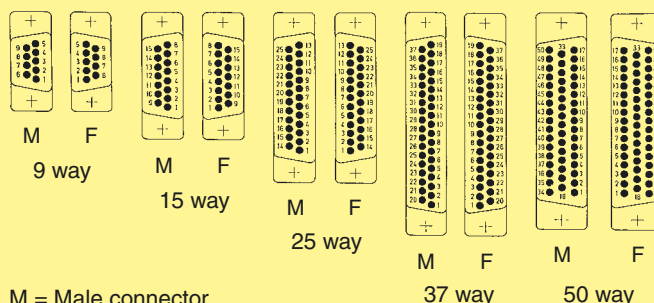

Mating conditions as per DIN 41 652

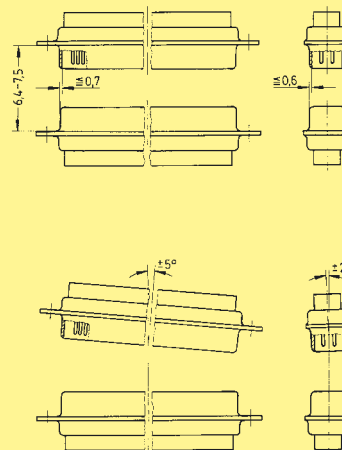

Press-in technology

<sup>1)</sup> Performance level 3, 50 mating cycles, no gas test  
Performance level 2 as per CECC 75 301-802, 250 mating cycles, 4 days 4 mixed gas test – IEC 60 512  
Performance level 1 as per CECC 75 301-802, 500 mating cycles, 10 days 4 mixed gas test – IEC 60 512



Number of contacts

# 9-50

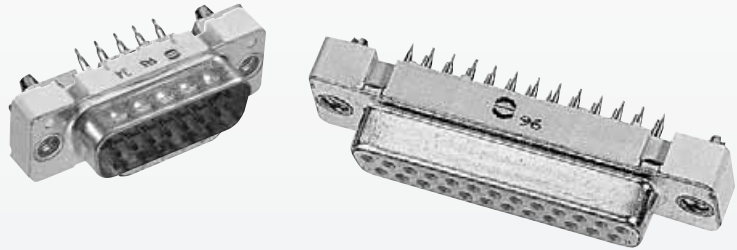

Press-in, straight with grounding press-in board locks

| Identification  | No. of contacts           | Part No.  |   |
|---|---------------------------|---|---|
| <b>Performance levels</b><br>Explanations see page 20.08<br>Other performance levels on request |                           | Performance level<br><b>3</b>   | Performance level<br><b>2</b>   |
| <b>Male connector</b><br>Flange height x = 5.7 mm   |                           |   |   |
| metal shell with dimples  | 9<br>15<br>25             | 09 66 164 771 .<br>09 66 264 771 .<br>09 66 364 771 .                                       | 09 66 164 671 .<br>09 66 264 671 .<br>09 66 364 671 .                                       |
| Please insert digit for flange thread<br>or fitted female screw locks                           |                           |   |   |
| M3 ▶ 5<br>4-40 UNC ▶ 6<br>fitted screw locks 4-40 UNC ▶ 7 <sup>1)</sup>                         |                           |   |   |
| <b>Female connector</b><br>Flange height x = 5.7 mm   |                           |   |   |
| metal shell   | 9<br>15<br>25<br>37       | 09 66 154 751 .<br>09 66 254 751 .<br>09 66 354 751 .<br>09 66 454 751 .                    | 09 66 154 651 .<br>09 66 254 651 .<br>09 66 354 651 .<br>09 66 454 651 .                    |
| Please insert digit for flange thread<br>or fitted female screw locks                           |                           |   |   |
| M3 ▶ 5<br>4-40 UNC ▶ 6<br>fitted screw locks 4-40 UNC ▶ 7 <sup>1)</sup>                         |                           |   |   |
| <b>Female connector</b><br>Flange height x = 6 mm   |                           |   |   |
| metal shell   | 9<br>15<br>25<br>37<br>50 | 09 66 154 751 .<br>09 66 254 751 .<br>09 66 354 751 .<br>09 66 454 751 .<br>09 66 554 751 . | 09 66 154 651 .<br>09 66 254 651 .<br>09 66 354 651 .<br>09 66 454 651 .<br>09 66 554 651 . |
| Please insert digit for flange thread<br>or fitted female screw locks                           |                           |   |   |
| M3 ▶ 1<br>4-40 UNC ▶ 2<br>fitted screw locks 4-40 UNC ▶ 3 <sup>1)</sup>                         |                           |   |   |

Press-in technology

20  
10

<sup>1)</sup> Fitted screw locks 4-40 UNC not normally kept in stock for performance level 3  
 Connector dimensions see page 20.11. Mating conditions see page 20.08.

Number of contacts

# 9-50

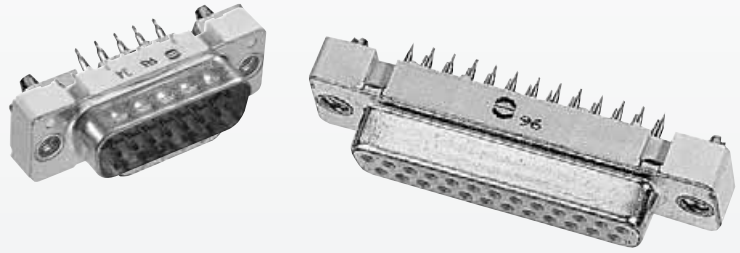

Press-in, straight with grounding press-in board locks

Identification

Drawing

Dimensions in mm

**Male connector**  
9 – 25 contacts

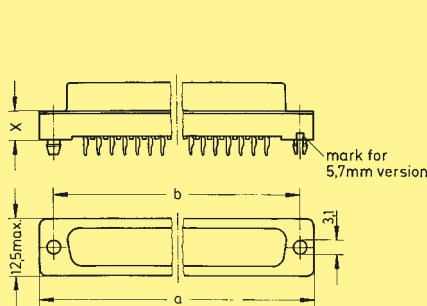

M 3 or 4 - 40 UNC      fitted screw locks 4 - 40 UNC

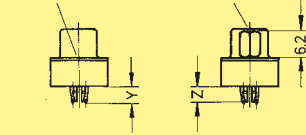

| X         | Y          | Z        |
|-----------|------------|----------|
| 6.0 ± 0.2 | 4.20 ± 0.2 | 3.5 max. |
| 5.7 ± 0.2 | 4.35 ± 0.2 | 3.9 max. |

**Female connector**  
9 – 37 contacts

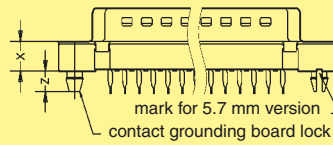

M 3 or 4 - 40 UNC      fitted screw locks 4 - 40 UNC

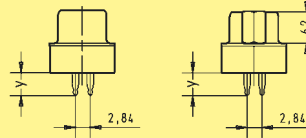

Mating face acc. to: DIN 41 652 · CECC 75 301-802 · IEC 60 807

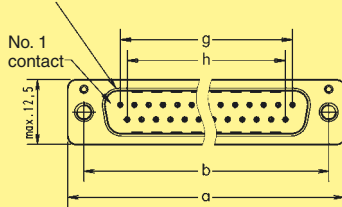

|    | a     | b     | g                   | h                   |
|----|-------|-------|---------------------|---------------------|
| 9  | 31.00 | 24.90 | 4 x [2.74] = 10.96  | 3 x [2.76] = 8.22   |
| 15 | 39.30 | 33.20 | 7 x [2.74] = 19.18  | 6 x [2.76] = 16.44  |
| 25 | 53.10 | 47.00 | 12 x [2.76] = 33.12 | 11 x [2.76] = 30.36 |
| 37 | 69.65 | 63.55 | 18 x [2.76] = 49.68 | 17 x [2.76] = 46.92 |
| 50 | 67.00 | 61.10 | 16 x [2.76] = 44.16 | 15 x [2.76] = 41.40 |

**Female connector**  
50 contacts

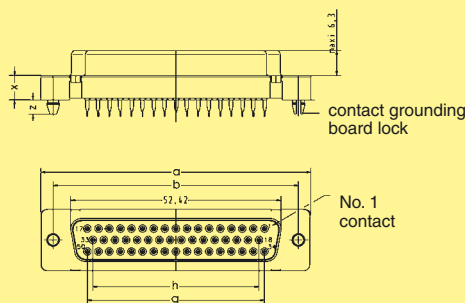

M 3 or 4 - 40 UNC      fitted screw locks 4 - 40 UNC

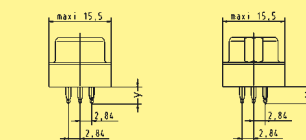

**Board drillings**

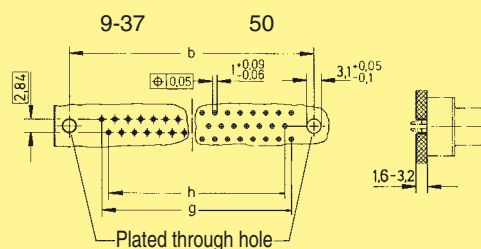

Press-in technology

Number of contacts

# 9-50

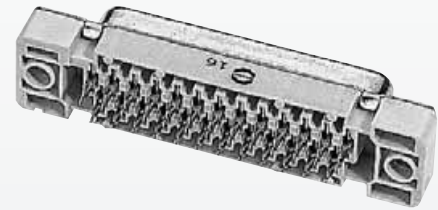
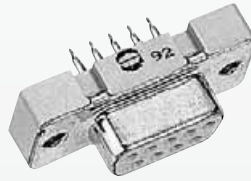

Press-in, straight without grounding press-in board locks

| Identification   | No. of contacts           | Part No.  |   |
|--|---------------------------|---|---|
| <b>Performance levels</b><br>Explanations see page 20.08<br>Other performance levels on request            |                           | Performance level<br><b>3</b>   | Performance level<br><b>2</b>   |
| <b>Male connector</b><br>Flange height x = 5.7 mm  |                           |   |   |
| metal shell with dimples   | 9<br>15<br>25             | 09 66 124 770 .<br>09 66 224 770 .<br>09 66 324 770 .                                       | 09 66 124 670 .<br>09 66 224 670 .<br>09 66 324 670 .                                       |
| Please insert digit for flange thread<br>or fitted female screw locks                                      |                           |   |   |
| ø 3.1 mm hole ▶ 4 <sup>1)</sup><br>M3 ▶ 5<br>4-40 UNC ▶ 6<br>fitted screw locks 4-40 UNC ▶ 7 <sup>2)</sup> |                           |   |   |
| <b>Female connector</b><br>Flange height x = 5.7 mm  |                           |   |   |
| metal shell  | 9<br>15<br>25<br>37       | 09 66 114 750 .<br>09 66 214 750 .<br>09 66 314 750 .<br>09 66 414 750 .                    | 09 66 114 650 .<br>09 66 214 650 .<br>09 66 314 650 .<br>09 66 414 650 .                    |
| Please insert digit for flange thread<br>or fitted female screw locks                                      |                           |   |   |
| ø 3.1 mm hole ▶ 4 <sup>1)</sup><br>M3 ▶ 5<br>4-40 UNC ▶ 6<br>fitted screw locks 4-40 UNC ▶ 7 <sup>2)</sup> |                           |   |   |
| <b>Female connector</b><br>Flange height x = 6 mm  |                           |   |   |
| metal shell  | 9<br>15<br>25<br>37<br>50 | 09 66 114 750 .<br>09 66 214 750 .<br>09 66 314 750 .<br>09 66 414 750 .<br>09 66 514 750 . | 09 66 114 650 .<br>09 66 214 650 .<br>09 66 314 650 .<br>09 66 414 650 .<br>09 66 514 650 . |
| Please insert digit for flange thread<br>or fitted female screw locks                                      |                           |   |   |
| ø 3.1 mm hole ▶ 0 <sup>1)</sup><br>M3 ▶ 1<br>4-40 UNC ▶ 2<br>fitted screw locks 4-40 UNC ▶ 3 <sup>2)</sup> |                           |   |   |

Press-in technology

1) Not normally kept in stock  
 2) Fitted screw locks 4-40 UNC not normally kept in stock for performance level 3  
 Connector dimensions see page 20.13. Mating conditions see page 20.08.

Number of contacts

# 9-50

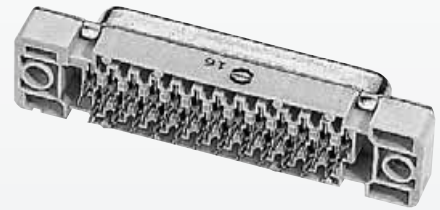
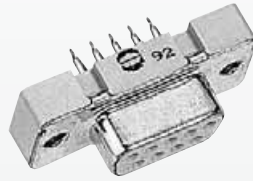

Press-in, straight without grounding press-in board locks

Identification

Drawing

Dimensions in mm

**Male connector**  
9 – 25 contacts

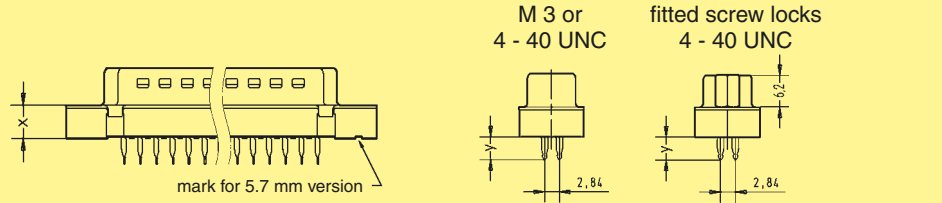

Mating face acc. to: DIN 41 652 · CECC 75 301-802 · IEC 60 807

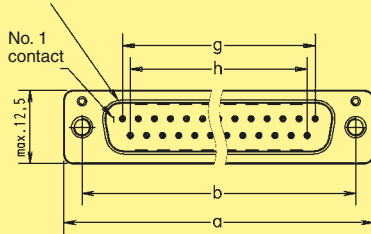

| X         | Y          |
|-----------|------------|
| 6.0 ± 0.2 | 4.20 ± 0.2 |
| 5.7 ± 0.2 | 4.35 ± 0.2 |

**Female connector**  
9 – 37 contacts

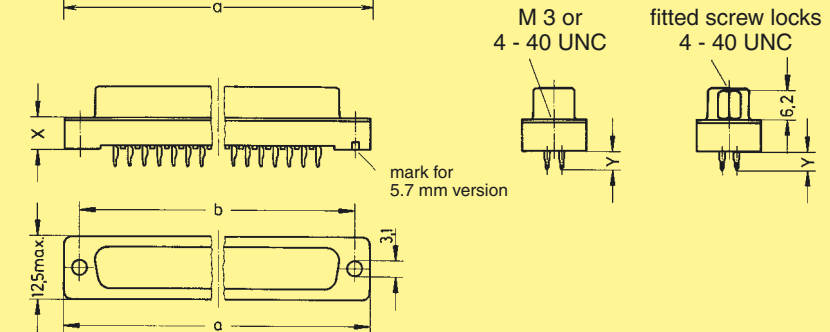

**Female connector**  
50 contacts

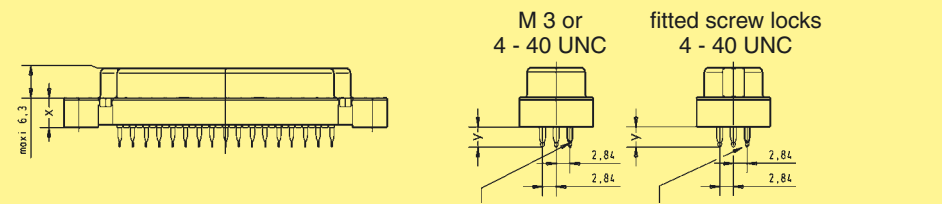

Press-in pins from position 34 to 50 are reversed 180 degrees

Mating face acc. to: DIN 41 652 · CECC 75 301-802 · IEC 60 807

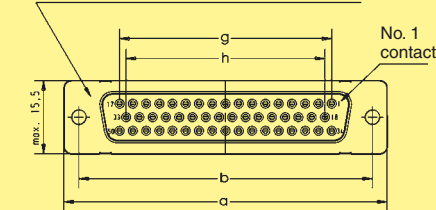

|    | a     | b     | g                   | h                   |
|----|-------|-------|---------------------|---------------------|
| 9  | 31.00 | 24.90 | 4 x [2.74] = 10.96  | 3 x [2.74] = 8.22   |
| 15 | 39.30 | 33.20 | 7 x [2.74] = 19.18  | 6 x [2.74] = 16.44  |
| 25 | 53.10 | 47.00 | 12 x [2.76] = 33.12 | 11 x [2.76] = 30.36 |
| 37 | 69.65 | 63.55 | 18 x [2.76] = 49.68 | 17 x [2.76] = 46.92 |
| 50 | 67.00 | 61.10 | 16 x [2.76] = 44.16 | 15 x [2.76] = 41.40 |

Board drillings

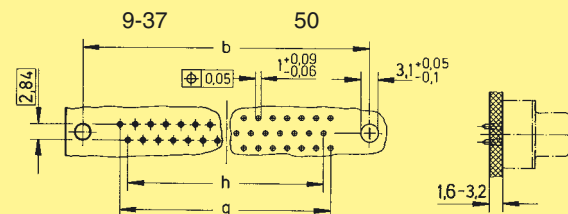

Press-in technology

|   |   |
|---|---|
| Number of contacts  | 6, 10, 14, 16, 20, 26, 34,<br>40, 50, 60, 64  |
| Contact arrangement   | straight  |
| Contact length  | 5.5 mm  |
| Approvals   | IEC 60 603-13<br>DIN EN 60 603-13<br>D 2632<br>BT 224<br>NFC 93-428 (HE 10)<br><br>UL recognized: E102079<br><br>comply with MIL DTL 83 503 |
|  |   |
| Pitch   | 2.54 mm [0.100"]  |
| Working current   | 1 A   |
| Test voltage $U_{r.m.s.}$   | 1 kV  |
| Contact resistance  | $\leq 20 \text{ m}\Omega$   |
| Insulation resistance   | $\geq 10^9 \Omega$  |
| Temperature range   | -55 °C ... + 105 °C<br>The maximum temperature includes heating of contacts and ambient temperature   |
| Press-in  |   |
| Diameter of pcb plated through holes  | $\varnothing 1.0^{+0.09}_{-0.06} \text{ mm}$  |
| Recommended pcb holes for press-in process  | Hole: $\varnothing 1.12 - 1.15 \text{ mm}$<br>Cu : 25 – 75 $\mu\text{m}$<br>Sn : 5 – 15 $\mu\text{m}$                                       |
| Pcb thickness   | 1.6 – 3.2 mm  |
| Materials   |   |
| Moulding  | Thermoplastic resin (PBTP)<br>UL 94-V0  |
| Contact surface   |   |
| Contact zone  | gold-plated according to performance level <sup>1)</sup>  |

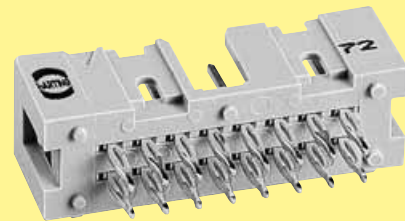

<sup>1)</sup> Performance level 3 as per IEC 60 603-13,  $\geq 50$  mating cycles, no gas test  
Performance level 2 as per IEC 60 603-13,  $\geq 250$  mating cycles, 4 days gas test  
as per MIL DTL 83 503,  $> 0.76 \mu\text{m Au}$  (30  $\mu$  inch), other performance levels on request

Number of contacts

# 6-64

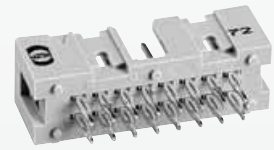

## Male header, straight press-in pins

Identification      No. of contacts      Part No.      Drawing      Dimensions in mm

Male header with straight press-in terminations  
Length: 5.5 mm

| No. of contacts | Part No.  | Drawing |
|-----------------|-----------|---------|
| 6               | 09 18 506 | 329     |
| 10              | 09 18 510 | 329     |
| 14              | 09 18 514 | 329     |
| 16              | 09 18 516 | 329     |
| 20              | 09 18 520 | 329     |
| 26              | 09 18 526 | 329     |
| 34              | 09 18 534 | 329     |
| 40              | 09 18 540 | 329     |
| 50              | 09 18 550 | 329     |
| 60              | 09 18 560 | 329     |
| 64              | 09 18 564 | 329     |

| No. of contacts | A    | B     | E                 |
|-----------------|------|-------|-------------------|
| 6               | 15.2 | 12.78 | 2.54 x 2 = 5.08   |
| 10              | 20.3 | 17.86 | 2.54 x 4 = 10.16  |
| 14              | 25.4 | 22.94 | 2.54 x 6 = 15.24  |
| 16              | 27.9 | 25.48 | 2.54 x 7 = 17.78  |
| 20              | 33.0 | 30.56 | 2.54 x 9 = 22.86  |
| 26              | 40.6 | 38.18 | 2.54 x 12 = 30.48 |
| 34              | 50.8 | 48.34 | 2.54 x 16 = 40.64 |
| 40              | 58.4 | 55.96 | 2.54 x 19 = 48.26 |
| 50              | 71.3 | 68.66 | 2.54 x 24 = 60.96 |
| 60              | 84.0 | 81.36 | 2.54 x 29 = 73.66 |
| 64              | 89.1 | 86.44 | 2.54 x 31 = 78.74 |

Marking No. 1 contact

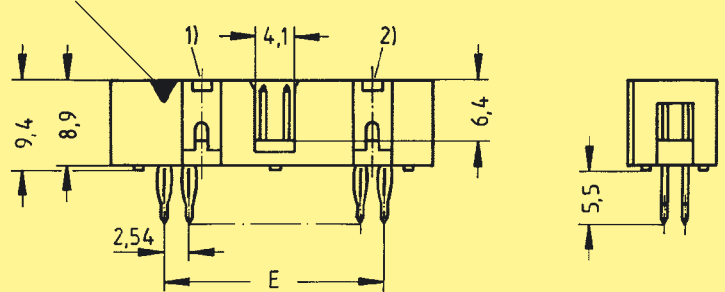

No. 2 contact

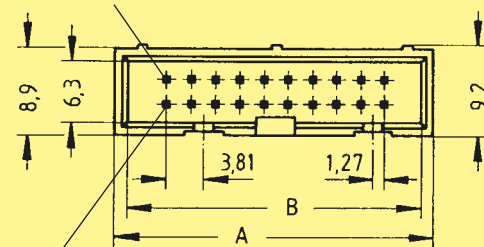

No. 1 contact

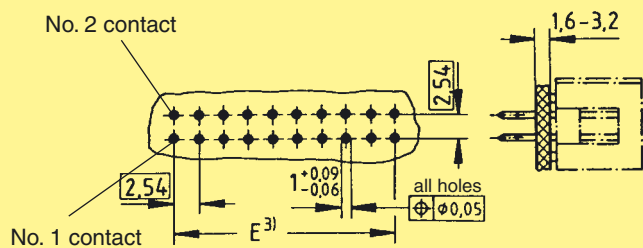

Board drillings

For Performance Level 3 please specify digit  
For Performance Level 2 please specify digit  
> 0.76 µm Au (30 µinch) on request

7  
6  
5 Not normally kept in stock

<sup>1)</sup> No polarization slot for 6, 10 or 14 way

<sup>2)</sup> No polarization slot for 6 way

<sup>3)</sup> Pitch tolerance: ± 0.1

